

Building construction — Organization of information about construction works — Part 3: Framework for object-oriented information — revised version 3

Warning

This document is not an ISO International Standard. It is distributed for review and comment. It is subject to change without notice and may not be referred to as an International Standard.

Recipients of this document are invited to submit, with their comments, notification of any relevant patent rights of which they are aware and to provide supporting documentation.

Document type: International Standard (Draft)
Document subtype: Not applicable
Document stage: Submitted by TC59/SC13/WG6 for Draft International Standard (DIS)
Document language: E

Copyright notice

This ISO document is a working draft or committee draft and is copyright-protected by ISO. While the reproduction of working drafts or committee drafts in any form for use by participants in the ISO standards development process is permitted without prior permission from ISO, neither this document nor any extract from it may be reproduced, stored or transmitted in any form for any other purpose without prior written permission from ISO.

Requests for permission to reproduce this document for the purpose of selling it should be addressed as shown below or to ISO's member body in the country of the requester:

*[Indicate :
the full address
telephone number
fax number
telex number
and electronic mail address*

as appropriate, of the Copyright Manager of the ISO member body responsible for the secretariat of the TC or SC within the framework of which the draft has been prepared]

Reproduction for sales purposes may be subject to royalty payments or a licensing agreement.

Violators may be prosecuted.

Contents

FOREWORD.....	IV
INTRODUCTION	V
1 SCOPE	1
2 NORMATIVE REFERENCES	1
3 TERMS AND DEFINITIONS	1
4 LANGUAGE ENCODING.....	1
5 SPECIFICATION.....	1
XTDDATE	8
XTDGLOBALUNIQUEID	8
XTDLABEL.....	9
XTDTEXT.....	9
XTDVERSIONID	9
XTDTOLERANCETYPEENUM	9
XTDVALUEROLEENUM.....	10
XTDVALUETYPEENUM	10
XTDACTIVITY	10
XTDACTOR	11
XTDBAG.....	11
XTDCOLLECTION	11
XTDDescription	11
XTDEXTERNALDOCUMENT	12
XTDLANGUAGE.....	12
XTDLANGUAGEREPRESENTATION	13
XTDMEASUREWITHUNIT	13
XTDNAME.....	14
XTDNEST	14
XTDOBJECT	14
XTDPROPERTY	15
XTDRELACTSUPON	15
XTDRELASSIGNSCOLLECTIONS	15
XTDRELASSIGNSMEASURES.....	16
XTDRELASSIGNSPROPERTIES.....	16
XTDRELASSIGNSPROPERTYWITHVALUES	16
XTDRELASSIGNSUNITS.....	17
XTDRELASSIGNSVVALUES.....	17
XTDRELASSOCIATES	18
XTDRELCOLLECTS	18
XTDRELCOMPOSES	18
XTDRELDOCUMENTS	19
XTDRELGROUPS	19
XTDRELSEQUENCES.....	20
XTDRELSPECIALIZES.....	20
XTDRELATIONSHIP.....	21
XTDROOT.....	21
XTDSUBJECT.....	21
XTDUNIT	22
XTDVALUE	22
CONVENTIONS	29

Foreword

ISO (the International Organization for Standardization) is a worldwide federation of national standards bodies (ISO member bodies). The work of preparing International Standards is normally carried out through ISO technical committees. Each member body interested in a subject for which a technical committee has been established has the right to be represented on that committee. International organizations, governmental and non-governmental, in liaison with ISO, also take part in the work. ISO collaborates closely with the International Electrotechnical Commission (IEC) on all matters of electrotechnical standardization.

International Standards are drafted in accordance with the rules given in the ISO/IEC Directives, Part 3.

The main task of technical committees is to prepare International Standards. Draft International Standards adopted by the technical committees are circulated to the member bodies for voting. Publication as an International Standard requires approval by at least 75 % of the member bodies casting a vote.

Attention is drawn to the possibility that some of the elements of this International Standard ISO/DIS 12006-3 may be the subject of patent rights. ISO shall not be held responsible for identifying any or all such patent rights.

ISO/DIS 12006-3 was prepared by Technical Committee ISO/TC 59 Building Construction, Subcommittee SC 13 Organization of information about construction works, Working Group 6.

ISO/DIS 12006-3 is a companion to ISO/ 12006-2:2001, *Organization of information about construction works – Part 2: Framework for classification of information*, which provides a framework for a classification. It is complementary to this standard. Each has an important role to play in the organization of information about construction works¹.

¹ ISO work item 12006-1 has been terminated some time ago.

Introduction

The main part of ISO/DIS 12006-3 consists of the specification of a taxonomy model, which provides the ability to define concepts by means of properties, to group concepts, and to define relationships between concepts. Objects, collections and relationships are the basic entities of the model. The set of properties associated with an object provide the formal definition of the object as well as its typical behaviour. Properties have values, optionally expressed in units.

The role that an object is intended to play can be designated through the model and this provides the capability to define the context within which the object is used. Each object may have multiple names and this allows for its expression in terms of synonyms or in multiple languages. The language name of each object must always be given in English (the default language). An object may also be named in terms of the language of the location in which it is determined or used. Objects may be related to formal classification systems through the provision of references.

The model has one Root entity from which the following three subtype entities inherit: Objects, Collections and the Relationships between them. The Root entity provides the ability to assign any set of names, labels, descriptions and references, in any language, to its derived types, as well as identifiers and dates.

Objects are divided into Subjects, Activities, Actors, Units, Measures with Units and Properties. Subjects and Activities are the things and processes that are described. The others are description entities related to other Objects and themselves through Relationships.

Relationships provide an association mechanism between Objects. Relationships are divided into Association, Collection, Specialization, Composition, Involvement (acting upon), Property assignment, Sequencing and Measure assignment.

Collections provide for all kinds of groupings of Objects, including nested Collections, by means of the Collect Relationship.

Properties are entities that provide the context for data stored as values. Properties are differentiated according to types of data containment: Enumeration values, List values, Bounded list values, Bounded values, Single values and Table values.

The value content, associated to a Property through a Measure with Unit, will be stored in the Value component, which is language dependent and therefore derived from the Language Representation class. The latter entity models the way any Name, Description, Value or Reference is represented on a per language base.

1 Scope

This Draft International Standard specifies a language-independent information model which can be used for the development of dictionaries used to store or provide information about construction works.

ISO/DIS 12006-3 enables classification systems, information models, object models and process models to be referenced from within a common framework.

2 Normative references

The following standards contain provisions which, through reference in this text, constitute provisions of this DIS. At the time of publication, the editions indicated were valid.

ISO 10303–11:1994 *Industrial automation systems and integration – Product data representation and exchange – Part 11: Description methods: The EXPRESS language reference manual.*

3 Terms and definitions

All terms having meaning in the context of this document are defined in the Specification that forms the body of this Standard:

4 Language encoding

All information that is specified as type 'String', or that resolves to type 'String', shall be able to be expressed using the UNICODE character set as set out in ISO/IEC 10646.

5 Specification

The model in this standard is described informally in the set of diagrams following, the diagrams conforming to the EXPRESS-G notation.

The model in this standard is described formally in the EXPRESS data definition language specification presented subsequently.

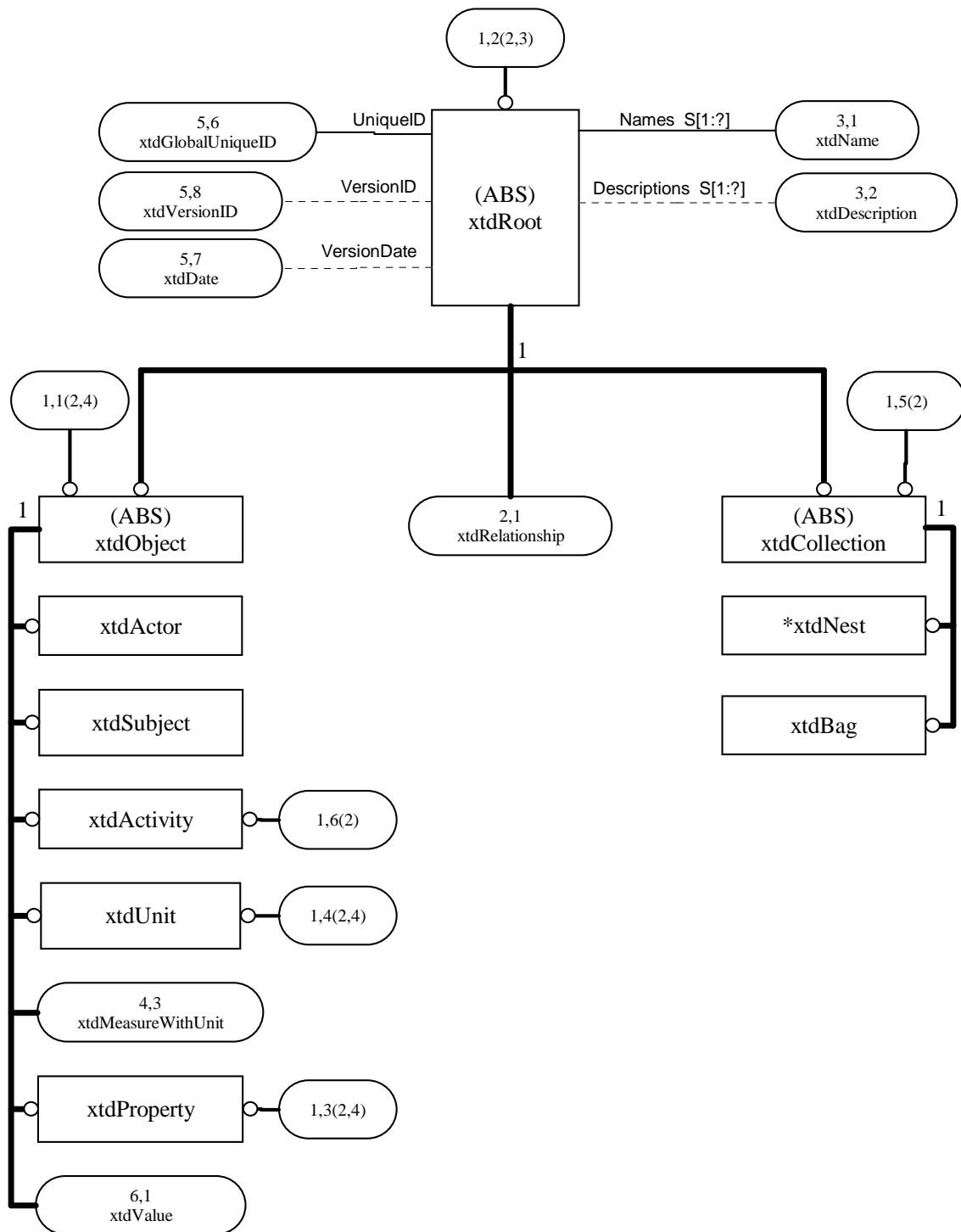

Figure 1 - EXPRESS-G diagram 1 of 6

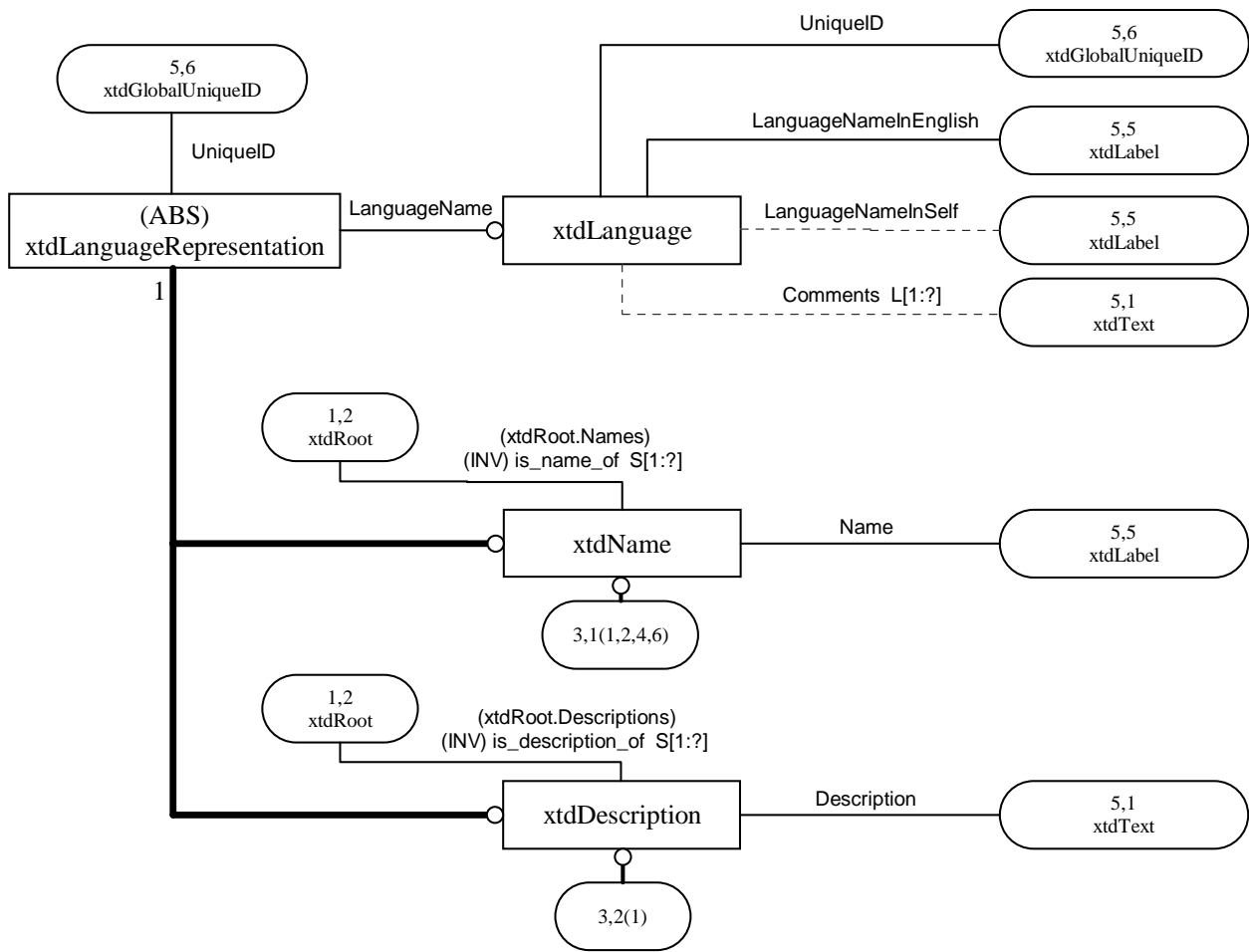

Figure 2 - EXPRESS-G diagram 2 of 6

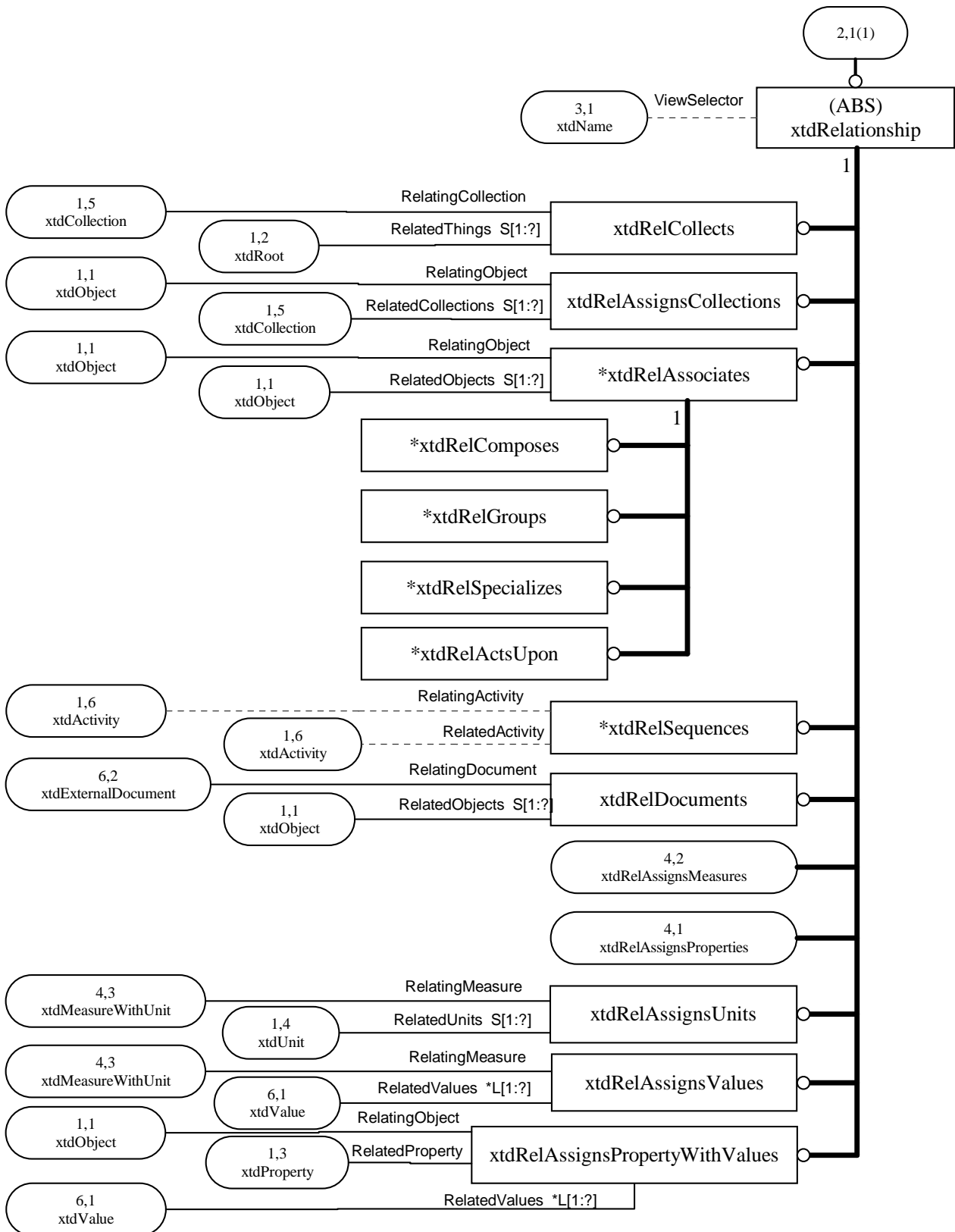

Figure 3 - EXPRESS-G diagram 3 of 6

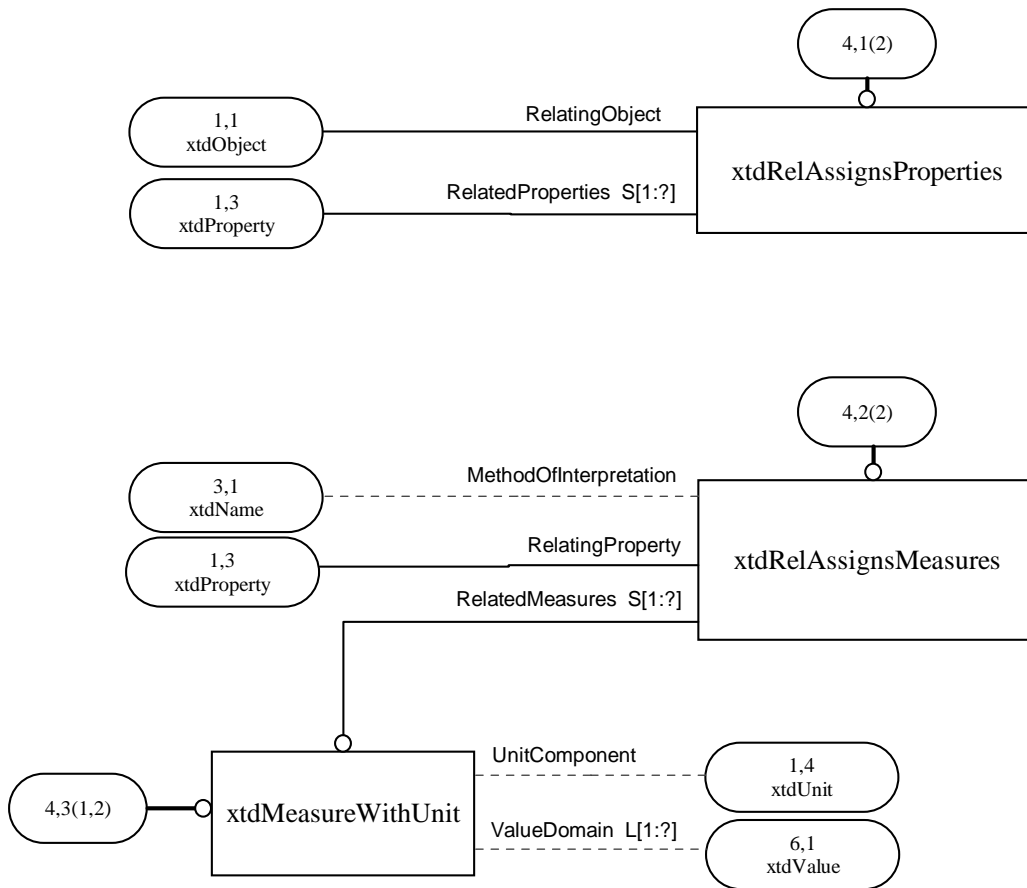

Figure 4 - EXPRESS-G diagram 4 of 6

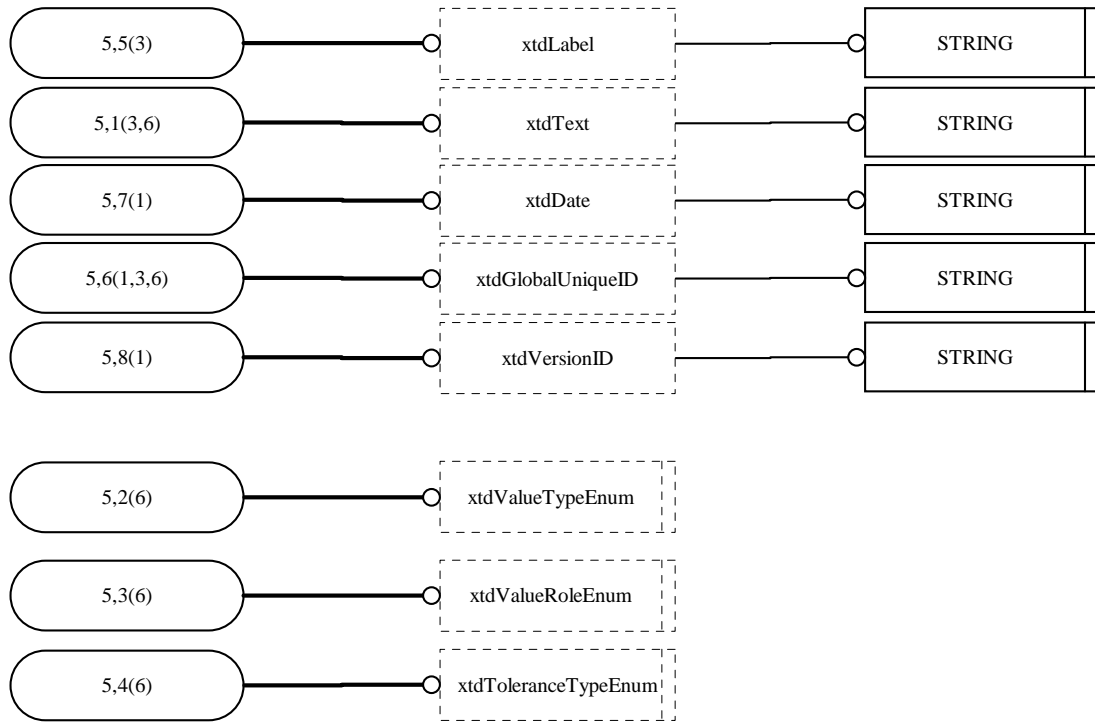

Figure 5 - EXPRESS-G diagram 5 of 6

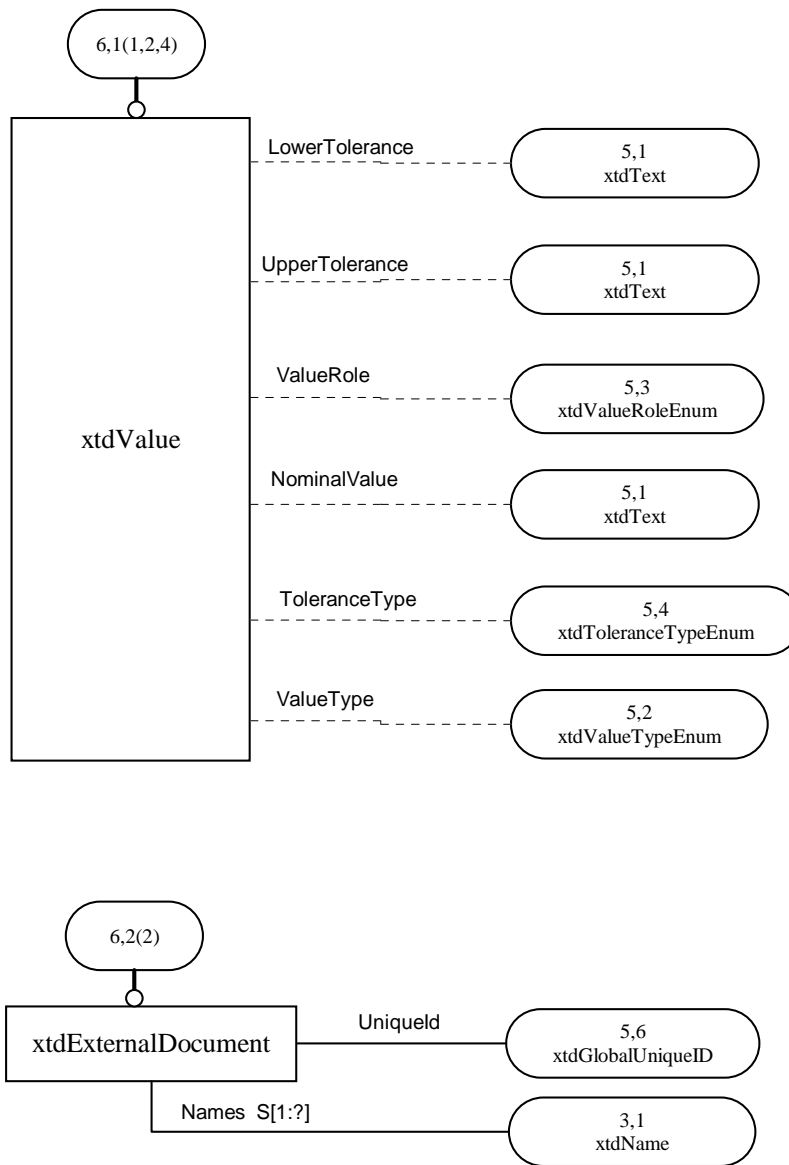

Figure 6 - EXPRESS-G diagram 6 of 6

EXPRESS specification:

```
*)
  TYPE xtdGlobalUniqueID = STRING;
  END_TYPE;
(*
```

xtdLabel

xtdLabel is a defined data type of simple data type STRING that is a set of alphanumeric UNICODE characters used to nominate an object.

EXPRESS specification:

```
*)
  TYPE xtdLabel = STRING;
  END_TYPE;
(*
```

xtdText

xtdText is a defined data type of simple data type STRING that is a set of alphanumeric UNICODE characters used to annotate an object.

EXPRESS specification:

```
*)
  TYPE xtdText = STRING;
  END_TYPE;
(*
```

xtdVersionID

xtdVersionID is a defined data type of simple data type STRING that is a set of alphanumeric UNICODE characters used to identity the version of an object.

EXAMPLE:

"1A", "12", "1.1" are types of versioning.

EXPRESS specification:

```
*)
  TYPE xtdVersionID = STRING;
  END_TYPE;
(*
```

xtdToleranceTypeEnum

xtdToleranceTypeEnum is an enumeration type giving the range of possible types of tolerances which can be applied to a value. Allowed selections are:

Realvalue Defined type of equal type as the value that expresses the tolerance as a real value.

Percentage Defined type that expresses the tolerance as a percentage of the value.

EXPRESS specification:

```
*)
  TYPE xtdToleranceTypeEnum = ENUMERATION OF
    (REALVALUE,
```

```
PERCENTAGE);  
END_TYPE;  
(*
```

xtdValueRoleEnum

xtdValueRoleEnum is an enumeration type giving the range of possible types of interpretation which can be applied to a value. Allowed selections are:

Nominal Defined type of denominating the value of type nominal.
Maximum Defined type of denominating the value as a maximum value.
Minimum Defined type of denominating the value as a minimum value.

EXPRESS specification:

```
*)  
TYPE xtdValueRoleEnum = ENUMERATION OF  
  (NOMINAL,  
   MAXIMUM,  
   MINIMUM);  
END_TYPE;  
(*
```

xtdValueTypeEnum

xtdValueTypeEnum is an enumeration type giving the range of possible simple value types from which a selection can be made. Allowed selections are:

xtdString Defined type of simple type STRING for descriptive purposes.
xtdNumber Defined type of simple type STRING
xtdInteger Defined type of simple type INTEGER.
xtdNumber Defined type of simple type REAL.
xtdBoolean Defined type of simple type BOOLEAN.
xtdLogical Defined type of simple type LOGICAL.

EXPRESS specification:

```
*)  
TYPE xtdValueTypeEnum = ENUMERATION OF  
  (XTDSTRING,  
   XTDNUMBER,  
   XTDINTEGER,  
   XTDREAL,  
   XTDBOOLEAN,  
   XTDLOGICAL);  
END_TYPE;  
(*
```

xtdActivity

xtdActivity is a specialization of xtdObject that represents an activity or process that modifies an xtdSubject.

EXAMPLE:

"bricklaying" represents the activity or process of bringing together bricks and mortar to create a wall or other element of construction.

EXPRESS specification:

```
*)
```

```

ENTITY xtdActivity
  SUBTYPE OF(xtdObject);
END_ENTITY;
(*)

```

xtdActor

xtdActor is a specialization of xtdObject that represents an agent that acts upon an xtdSubject within an xtdActivity.

EXAMPLE:

An actor can be a person, profession, organizational unit, equipment.

"carpenter" is an xtdActor.

"ISO" is an xtdActor.

"crane" may be used as an xtdActor.

EXPRESS specification:

```

*)
ENTITY xtdActor
  SUBTYPE OF(xtdObject);
END_ENTITY;
(*)

```

xtdBag

xtdBag is a specialization of xtdCollection that has no constraints on the things that can be members of the collection.

EXAMPLE:

A collection of actors and activities and subjects may be collected together within an instance of xtdBag.

EXPRESS specification:

```

*)
ENTITY xtdBag
  SUBTYPE OF(xtdCollection);
END_ENTITY;
(*)

```

xtdCollection

xtdCollection represents a group or collection of things. An xtdCollection can be one of xtdNest or xtdBag.

EXPRESS specification:

```

*)
ENTITY xtdCollection
  ABSTRACT SUPERTYPE OF (ONEOF(xtdNest, xtdBag))
  SUBTYPE OF(xtdRoot);
END_ENTITY;
(*)

```

xtdDescription

xtdDescription holds the description or definition of a thing by means of text.

EXAMPLE:

"A door leaf is the part of a door that opens to allow people or goods to pass" is the definitive description in English for the object "Door leaf".

EXPRESS specification:

```
*)
  ENTITY xtdDescription
    SUBTYPE OF(xtdLanguageRepresentation);
    Description          :xtdText;
  INVERSE
    is_description_of    :SET [1:?] OF xtdRoot FOR Descriptions;
  END_ENTITY;
```

(*

Attribute definitions:

Description : An instance of xtdText that holds the description or definition.

xtdExternalDocument

xtdExternalDocument is used to represent external documents, books or other written information.

EXAMPLE:

"ISO 31" is a document.
"NS 3420" is a document.

EXPRESS specification:

```
*)
  ENTITY xtdExternalDocument;
    UniqueId            :xtdGlobalUniqueID;
    Names                :SET [1:?] OF xtdName;
  END_ENTITY;
```

(*

Attribute definitions:

Uniqueld : The globally unique identifier for the external document.
Names : A set of language dependent names of the external document.

xtdLanguage

xtdLanguage represents the language in which names, descriptions, values and references are expressed including its designation in itself and in English.

EXPRESS specification:

```
*)
  ENTITY xtdLanguage;
    LanguageNameInEnglish :xtdLabel;
    LanguageNameInSelf    :OPTIONAL xtdLabel;
    Comments               :OPTIONAL LIST [1:?] OF xtdText;
    UniqueID              :xtdGlobalUniqueID;
  END_ENTITY;
```

(*

Attribute definitions:

LanguageNameInEnglish : The name of the language in which the identifying descriptive attribute is expressed in the form in which the language is known in English. The name should be interpreted in a non case sensitive way.

EXAMPLE:

"English" is the ISO3166 name for all types of English.

LanguageNameInSelf : German is the name in English of the language spoken in Germany and surrounding countries.
: The name of the language in which the identifying descriptive attribute is expressed in the form in which the language is known in itself.

EXAMPLE:

"Deutsch" is the name by which German language is known to German language speakers.

"Norsk nynorsk" is the name of a particular form of the Norwegian language
"British English" is the name of the form of the English language which is characterized by the spelling and intonation used within the British Isles and certain other parts of the world.

Comments : An optional list of comments for the language used.
UniqueID : The globally unique identifier for the language.

xtdLanguageRepresentation

xtdLanguageRepresentation is a representation of the language used to specify a name, a description, a value or a reference.

EXPRESS specification:

```
*)
ENTITY xtdLanguageRepresentation
  ABSTRACT SUPERTYPE OF (ONEOF(xtdName, xtdDescription));
  LanguageName          : xtdLanguage;
  UniqueID              : xtdGlobalUniqueID;
END_ENTITY;
```

(*

Attribute definitions:

LanguageName : The name of the language used for the xtdLanguageRepresentation.
UniqueID : The globally unique identifier for the language representation.

xtdMeasureWithUnit

xtdMeasureWithUnit is a specialization of xtdObject that makes an xtdProperty measurable by associating a unit to a value.

EXAMPLE:

"1m" is an an instance of xtdMeasureWithUnit with a unit component "m" and a value component "1".

"AB88" is an instance of xtdMeasureWithUnit with a value component "AB88" and no unit component.

EXPRESS specification:

```
*)
ENTITY xtdMeasureWithUnit
  SUBTYPE OF(xtdObject);
  UnitComponent          : OPTIONAL xtdUnit;
  ValueDomain           : OPTIONAL LIST [1:?] OF xtdValue;
END_ENTITY;
```

(*

Attribute definitions:

UnitComponent : The unit in which the value is expressed.
ValueDomain : The value domain for the measure for the given unit.

xtdName

xtdName is a language dependent name given to an object. An object may have several names in the same language and names do not need to be unique for a single object.

EXAMPLE:

"beam" and "truss" are both English names for the same object.
"bjelke" is the Norwegian name for the English "beam".

EXPRESS specification:

```
*)
  ENTITY xtdName
    SUBTYPE OF(xtdLanguageRepresentation);
    Name :xtdLabel;
  INVERSE
    is_name_of :SET [1:?] OF xtdRoot FOR Names;
  END_ENTITY;
```

(*

Attribute definitions:

Name : A label holding the name of the object.

xtdNest

xtdNest is a specialization of xtdCollection that only allows things of the same type to be members of the collection.

EXAMPLE:

"Window properties" is an xtdNest whose members are only instances of xtdProperty.

EXPRESS specification:

```
*)
  ENTITY xtdNest
    SUBTYPE OF(xtdCollection);
  WHERE
    WR1 :SIZEOF(QUERY(Result <* SELF\xtdRelCollects.RelatedThings |
      NOT(TYPEOF(SELF\xtdRelCollects.RelatingCollection) =
        TYPEOF(Result)))) = 0 ;
  END_ENTITY;
```

(*

Formal Propositions:

WR1 The type of the Collection shall always be the same as the type of each thing, i.e. the Collection and all things that are members of it are of the same type.

xtdObject

xtdObject is a specialization of xtdRoot that is the abstract entity from which xtdProperty, xtdMeasureWithUnit, xtdActor, xtdUnit, xtdSubject and xtdActivity are derived.

EXPRESS specification:

```
*)
  ENTITY xtdObject
    ABSTRACT SUPERTYPE OF (ONEOF(xtdSubject, xtdActivity, xtdUnit, xtdProperty,
      xtdMeasureWithUnit, xtdActor, xtdValue))
    SUBTYPE OF(xtdRoot);
  END_ENTITY;
```

(*)

xtdProperty

xtdProperty is a specialization of xtdObject that is used to qualify or quantify an xtdObject.

EXAMPLE:

"Width" is an xtdProperty.

"Door width" is an xtdProperty. used to qualify the "Width" of the xtdSubject door.

"Heat transfer" is an xtdProperty.

"Colour" is an xtdProperty.

"Duration" is an xtdProperty.

"Comfort" is an xtdProperty.

EXPRESS specification:

*)

```
ENTITY xtdProperty
  SUBTYPE OF(xtdObject);
END_ENTITY;
```

(*)

xtdRelActsUpon

xtdRelActsUpon is a specialization of xtdRelAssociates representing one xtdObject acting upon one or more other xtdObjects.

EXAMPLE:

"A column supports a beam".

"A bricklayer lays bricks".

EXPRESS specification:

*)

```
ENTITY xtdRelActsUpon
  SUBTYPE OF(xtdRelAssociates);
WHERE
  WR1      : SIZEOF(QUERY(Result <* RelatedObjects | RelatingObject::: Result))
            = 0;
END_ENTITY;
```

(*)

Formal Propositions:

WR1 The instance to which the attribute relating object points shall not be contained in the Set of related objects.

xtdRelAssignsCollections

xtdRelAssignsCollections is a specialization of xtdRelationship that represents the assignment of one or more instances of xtdCollection to an xtdObject.

EXPRESS specification:

*)

```
ENTITY xtdRelAssignsCollections
  SUBTYPE OF(xtdRelationship);
  RelatingObject      : xtdObject;
  RelatedCollections  : SET [1:?] OF xtdCollection;
```

END_ENTITY;
(*

Attribute definitions:

RelatedCollections : A set of collections that is assigned to an object.
RelatingObject : The object to which the collections are assigned.

xtdRelAssignsMeasures

xtdRelAssignsMeasures is a specialization of xtdRelationship that represents the assignment of one or more instances of xtdMeasureWithUnit to an xtdProperty.

EXPRESS specification:

*)
ENTITY xtdRelAssignsMeasures
SUBTYPE OF(xtdRelationship);
RelatingProperty :xtdProperty;
RelatedMeasures :SET [1:?] OF xtdMeasureWithUnit;
MethodOfInterpretation :OPTIONAL xtdName;
END_ENTITY;

(*

Attribute definitions:

RelatedMeasures : A set of measures with unit that is assigned to a property.
RelatingProperty : The property to which the measures with unit are assigned.
MethodOfInterpretation : Method of interpretation is the explanation for the value component of a measure with unit.

EXAMPLE:

"Upper bound" is the method of interpretation for a measure with unit representing the upper bound of a bounded value.

xtdRelAssignsProperties

xtdRelAssignsProperties is a specialization of xtdRelationship that represents the assignment of one or more instances of xtdProperty to an xtdObject.

EXAMPLE:

"door height" is an xtdProperty assigned to the xtdObject "door".

EXPRESS specification:

*)
ENTITY xtdRelAssignsProperties
SUBTYPE OF(xtdRelationship);
RelatedProperties :SET [1:?] OF xtdProperty;
RelatingObject :xtdObject;
END_ENTITY;

(*

Attribute definitions:

RelatedProperties : A set of properties that is assigned to an object.
RelatingObject : The object to which the properties are assigned.

xtdRelAssignsPropertyWithValues

xtdRelAssignsPropertyWithValues is a specialization of xtdRelationship that is a ternary relationship representing the assignment of one or more related values from a complete set of values of a related property, on to a relating

object.

EXPRESS specification:

```
*)
  ENTITY xtdRelAssignsPropertyWithValues
    SUBTYPE OF(xtdRelationship);
    RelatedProperty          :xtdProperty;
    RelatingObject           :xtdObject;
    RelatedValues            :LIST [1:?] OF UNIQUE xtdValue;
  END_ENTITY;
```

(*

Attribute definitions:

RelatedProperty	: A property that contains the complete list of values in which the RelatedValues is selected.
RelatingObject	: The object to which the list of values is assigned.
RelatedValues	: The list of values selected from the complete set of values of the related property.

xtdRelAssignsUnits

xtdRelAssignsUnits is a specialization of xtdRelationship that represents the assignment of one or more instances of xtdUnit to a xtdMeasureWithUnit.

EXPRESS specification:

```
*)
  ENTITY xtdRelAssignsUnits
    SUBTYPE OF(xtdRelationship);
    RelatingMeasure          :xtdMeasureWithUnit;
    RelatedUnits             :SET [1:?] OF xtdUnit;
  END_ENTITY;
```

(*

Attribute definitions:

RelatedUnits	: A set of units that is assigned to a measure.
RelatingMeasure	: The measure to which the units are assigned.

xtdRelAssignsValues

xtdRelAssignsValues is a specialization of xtdRelationship that represents the assignment of one or more instances of xtdValue to a xtdMeasureWithUnit.

EXPRESS specification:

```
*)
  ENTITY xtdRelAssignsValues
    SUBTYPE OF(xtdRelationship);
    RelatingMeasure          :xtdMeasureWithUnit;
    RelatedValues            :LIST [1:?] OF UNIQUE xtdValue;
  END_ENTITY;
```

(*

Attribute definitions:

RelatedValues	: A list of values that is assigned to a measure.
RelatingMeasure	: The measure to which the values are assigned.

xtdRelAssociates

xtdRelAssociates is a specialization of xtdRelationship that represents the association of a relating xtdObject to a set of related instances of xtdObject.

EXPRESS specification:

```
*)
ENTITY xtdRelAssociates
  SUPERTYPE OF (ONEOF(xtdRelComposes, xtdRelGroups, xtdRelSpecializes,
                      xtdRelActsUpon))
  SUBTYPE OF(xtdRelationship);
  RelatingObject          :xtdObject;
  RelatedObjects          :SET [1:?] OF xtdObject;
WHERE
  WR1          :SIZEOF(QUERY(Result <* RelatedObjects | RelatingObject:=: Result))
               = 0;
END_ENTITY;
```

(*

Attribute definitions:

RelatedObjects : A set of objects that is associated with a target object.
 RelatingObject : The object that is the target of the relationship.

Formal Propositions:

WR1 The instance to which the attribute relating object points shall not be contained in the Set of related objects.

xtdRelCollects

xtdRelCollects is a specialization of xtdRelationship that represents the collecting of arbitrary entities into a xtdCollection. xtdCollection is instantiated as either an xtdNest or as an xtdBag.

EXPRESS specification:

```
*)
ENTITY xtdRelCollects
  SUBTYPE OF(xtdRelationship);
  RelatedThings          :SET [1:?] OF xtdRoot;
  RelatingCollection     :xtdCollection;
END_ENTITY;
```

(*

Attribute definitions:

RelatedThings : A set of things making up a collection.
 RelatingCollection : The collection of things, where each instance in the collection is an object or relationship.

xtdRelComposes

xtdRelComposes is a specialization of xtdRelAssociates that represents an xtdObject as being composed of other instances of xtdObject. The composition relationship can be applied recursively so that a composed xtdObject can be a part of another composed xtdObject.

EXAMPLE:

A 'door frame' and a 'door leaf' are a 'part of' the (whole) 'door set'.

EXPRESS specification:

```

*)
  ENTITY xtdRelComposes
    SUBTYPE OF(xtdRelAssociates);
  WHERE
    WR1      : SIZEOF(QUERY(Result <* SELF\xtdRelComposes.RelatedObjects |
                       NOT(TYPEOF(SELF\xtdRelComposes.RelatingObject) = TYPEOF(Result))))
              = 0 ;
    WR2      : SIZEOF(QUERY(Result2 <* RelatedObjects | RelatingObject:::
                       Result2)) = 0 ;
  END_ENTITY;

```

(*)

Formal Propositions:

- WR1 The type of the relating object shall always be the same as the type of each related object. i.e. instances of xtdSubject are composed only of other instances of xtdSubject.
- WR2 The instance to which the attribute relating object points shall not be contained in the List of related objects.

xtdRelDocuments

xtdRelDocuments is a specialization of xtdRelationship that handles the documentation of objects by relating objects to the documents where they are described. Each document can relate to many objects.

EXPRESS specification:

```

*)
  ENTITY xtdRelDocuments
    SUBTYPE OF(xtdRelationship);
    RelatedObjects      : SET [1:?] OF xtdObject;
    RelatingDocument   : xtdExternalDocument;
  END_ENTITY;

```

(*)

Attribute definitions:

- RelatedObjects : A set of objects that are described in the external document.
- RelatingDocument : The external document describing the related objects.

xtdRelGroups

xtdRelGroups is a specialization of xtdRelationship that represents the grouping of a set of related instances of xtdObject into a relating xtdObject.

EXPRESS specification:

```

*)
  ENTITY xtdRelGroups
    SUBTYPE OF(xtdRelAssociates);
  WHERE
    WR1      : SIZEOF(QUERY(Result <* RelatedObjects | RelatingObject::: Result))
              = 0 ;
  END_ENTITY;

```

(*)

Formal Propositions:

- WR1 The instance to which the attribute relating object points shall not be contained in the List of related objects.

xtdRelSequences

xtdRelSequences is a specialization of xtdRelationship that represents the sequencing between two instances of xtdActivity. The relating xtdActivity precedes the related xtdActivity in a sequence.

EXPRESS specification:

```
*)
ENTITY xtdRelSequences
  SUBTYPE OF(xtdRelationship);
  RelatingActivity      :OPTIONAL xtdActivity;
  RelatedActivity       :OPTIONAL xtdActivity;
WHERE
  WR1      :RelatedActivity:<>: RelatingActivity;
  WR2      :EXISTS(RelatingActivity) OR EXISTS(RelatedActivity);
END_ENTITY;
```

(*

Attribute definitions:

RelatedActivity : Reference to the succeeding activity in a sequence.
 RelatingActivity : Reference to the preceding activity in a sequence.

Formal Propositions:

WR1 The relating activity shall not point to the same instance as the related activity.
 WR2 One of relating activity or related activity must be asserted.

xtdRelSpecializes

xtdRelSpecializes is a specialization of xtdAssociates that represents the specialization of a supertype into one or more subtypes, ensuring that a subtype is more constrained than the supertype.

EXAMPLE:

"outer door" is a specialization of "door".
 "space" is the generalization of "room".

EXPRESS specification:

```
*)
ENTITY xtdRelSpecializes
  SUBTYPE OF(xtdRelAssociates);
WHERE
  WR1      :SIZEOF(QUERY(Result <* RelatedObjects | RelatingObject::: Result))
            = 0;
  WR2      :SIZEOF(QUERY(Result <* SELF\xtdRelSpecializes.RelatedObjects |
            NOT(TYPEOF(SELF\xtdRelSpecializes.RelatingObject) =
            TYPEOF(Result)))) = 0 ;
END_ENTITY;
```

(*

Formal Propositions:

WR1 The instance to which the attribute relating object points shall not be contained in the list of related objects.
 WR2 The type of the relating object shall always be the same as the type of each related object i.e. an instance of xtdSubject can only be a specialization of another instance of xtdSubject.

xtdRelationship

xtdRelationship is a specialization of xtdRoot. It is an abstract entity that represents the objectification of relationships, allowing for additional attributes to be added to the entity.

EXPRESS specification:

```
*)
ENTITY xtdRelationship
  ABSTRACT SUPERTYPE OF (ONEOF(xtdRelAssociates, xtdRelAssignsProperties,
                                xtdRelAssignsMeasures, xtdRelCollects,
                                xtdRelAssignsCollections, xtdRelSequences,
                                xtdRelDocuments, xtdRelAssignsUnits, xtdRelAssignsValues,
                                xtdRelAssignsPropertyWithValues))
  SUBTYPE OF(xtdRoot);
  ViewSelector                : OPTIONAL xtdName;
END_ENTITY;
```

(*

Attribute definitions:

ViewSelector : An optional attribute used to qualify the relationship for the purpose of creating different views of the data.

EXAMPLE:

The ViewSelector "IFC 2x2" can be used to identify relationship originating from the IFC 2x2 model.

xtdRoot

xtdRoot is the abstract entity through which basic services of identifying, naming, versioning, description and referencing can be applied to instances of subtypes of xtdObject, xtdRelationship and xtdCollection.

EXPRESS specification:

```
*)
ENTITY xtdRoot
  ABSTRACT SUPERTYPE OF (ONEOF(xtdObject, xtdRelationship, xtdCollection));
  VersionDate                : OPTIONAL xtdDate;
  VersionID                  : OPTIONAL xtdVersionID;
  UniqueID                   : xtdGlobalUniqueID;
  Descriptions                : OPTIONAL SET [1:?] OF xtdDescription;
  Names                       : SET [1:?] OF xtdName;
END_ENTITY;
```

(*

Attribute definitions:

VersionDate : The date of the last revision of the reference data object.
 VersionID : The version number for the reference data version of the object.
 UniqueID : The global unique identifier for the object.
 Descriptions : A set of language dependent descriptions of the object.
 Names : A set of language dependent names of the object.

xtdSubject

xtdSubject is a specialization of xtdObject that is subject to description by associated properties and activities. An xtdSubject can be physical or logical.

EXAMPLE:

"Roof" is an xtdSubject.

"Lobby" is an xtdSubject.
"Control system" is an xtdSubject.
"Road" is an xtdSubject.
"Airport" is an xtdSubject.
"Software" is an xtdSubject.

EXPRESS specification:

```
*)  
  ENTITY xtdSubject  
    SUBTYPE OF(xtdObject);  
  END_ENTITY;  
(*
```

xtdUnit

xtdUnit is a specialization of xtdObject that represents a scale that enables a value to be measured.

EXAMPLE:

"metre" is xtdUnit, which can be represented by the symbol "m".
"W/m.K" is an xtdUnit used with the property "thermal conductivity".

EXPRESS specification:

```
*)  
  ENTITY xtdUnit  
    SUBTYPE OF(xtdObject);  
  END_ENTITY;  
(*
```

xtdValue

xtdValue is a specialization of xtdLanguageRpresentation that can hold the description of a value of an xtdProperty.

EXAMPLE:

"Vertikaal schuivend" is the Dutch value for "Vertical sliding".

EXPRESS specification:

```
*)  
  ENTITY xtdValue  
    SUBTYPE OF(xtdObject);  
    LowerTolerance           : OPTIONAL xtdText;  
    NominalValue             : OPTIONAL xtdText;  
    UpperTolerance           : OPTIONAL xtdText;  
    ValueType                : OPTIONAL xtdValueTypeEnum;  
    ValueRole                 : OPTIONAL xtdValueRoleEnum;  
    ToleranceType            : OPTIONAL xtdToleranceTypeEnum;  
  END_ENTITY;  
(*
```

Attribute definitions:

LowerTolerance	: Optional lower tolerance for the value.
NominalValue	: Optional text string holding the nominal value.
UpperTolerance	: Optional upper tolerance for the value.
ValueType	: Optional select type to define the type of value.
ValueRole	: Optional select type for the role of the value.
ToleranceType	: Optional select type to define the type tolerance for the value.

*)
END_SCHEMA;

EXPRESS Long Form Specification

```

SCHEMA ISO_12006_3_VERSION_3;
  TYPE xtdText = STRING;
  END_TYPE;

  TYPE xtdValueTypeEnum = ENUMERATION OF
    (XTDSTRING,
     XTDNUMBER,
     XTDINTEGER,
     XTDREAL,
     XTDBOOLEAN,
     XTDLOGICAL);
  END_TYPE;

  TYPE xtdValueRoleEnum = ENUMERATION OF
    (NOMINAL,
     MAXIMUM,
     MINIMUM);
  END_TYPE;

  TYPE xtdToleranceTypeEnum = ENUMERATION OF
    (REALVALUE,
     PERCENTAGE);
  END_TYPE;

  TYPE xtdLabel = STRING;
  END_TYPE;

  TYPE xtdGlobalUniqueID = STRING;
  END_TYPE;

  TYPE xtdDate = STRING;
  END_TYPE;

  TYPE xtdVersionID = STRING;
  END_TYPE;

  ENTITY xtdSubject
    SUBTYPE OF(xtdObject);
  END_ENTITY;

  ENTITY xtdObject
    ABSTRACT SUPERTYPE OF (ONEOF(xtdSubject, xtdActivity, xtdUnit, xtdProperty,
    xtdMeasureWithUnit, xtdActor, xtdValue))
    SUBTYPE OF(xtdRoot);
  END_ENTITY;

  ENTITY xtdRoot
    ABSTRACT SUPERTYPE OF (ONEOF(xtdObject, xtdRelationship, xtdCollection));
    VersionDate : OPTIONAL xtdDate;
    VersionID : OPTIONAL xtdVersionID;
    UniqueID : xtdGlobalUniqueID;
    Descriptions : OPTIONAL SET [1:?] OF xtdDescription;
    Names : SET [1:?] OF xtdName;
  END_ENTITY;

  ENTITY xtdRelationship
    ABSTRACT SUPERTYPE OF (ONEOF(xtdRelAssociates, xtdRelAssignsProperties,
    xtdRelAssignsMeasures, xtdRelCollects, xtdRelAssignsCollections, xtdRelSequences,

```

```

xtdRelDocuments, xtdRelAssignsUnits, xtdRelAssignsValues,
xtdRelAssignsPropertyWithValues))
  SUBTYPE OF(xtdRoot);
  ViewSelector : OPTIONAL xtdName;
END_ENTITY;

ENTITY xtdRelAssociates
  SUPERTYPE OF (ONEOF(xtdRelComposes, xtdRelGroups, xtdRelSpecializes,
xtdRelActsUpon))
  SUBTYPE OF(xtdRelationship);
  RelatingObject : xtdObject;
  RelatedObjects : SET [1:?] OF xtdObject;
  WHERE
    WR1 : SIZEOF(QUERY(Result <* RelatedObjects | RelatingObject::= Result)) = 0;
END_ENTITY;

ENTITY xtdRelComposes
  SUBTYPE OF(xtdRelAssociates);
  WHERE
    WR1 : SIZEOF(QUERY(Result <* SELF\xtdRelComposes.RelatedObjects |
NOT(TYPEOF(SELF\xtdRelComposes.RelatingObject) = TYPEOF(Result)))) = 0 ;
    WR2 : SIZEOF(QUERY(Result2 <* RelatedObjects | RelatingObject::= Result2)) = 0;
END_ENTITY;

ENTITY xtdRelGroups
  SUBTYPE OF(xtdRelAssociates);
  WHERE
    WR1 : SIZEOF(QUERY(Result <* RelatedObjects | RelatingObject::= Result)) = 0;
END_ENTITY;

ENTITY xtdRelSpecializes
  SUBTYPE OF(xtdRelAssociates);
  WHERE
    WR1 : SIZEOF(QUERY(Result <* RelatedObjects | RelatingObject::= Result)) = 0;
    WR2 : SIZEOF(QUERY(Result <* SELF\xtdRelSpecializes.RelatedObjects |
NOT(TYPEOF(SELF\xtdRelSpecializes.RelatingObject) = TYPEOF(Result)))) = 0 ;
END_ENTITY;

ENTITY xtdRelActsUpon
  SUBTYPE OF(xtdRelAssociates);
  WHERE
    WR1 : SIZEOF(QUERY(Result <* RelatedObjects | RelatingObject::= Result)) = 0;
END_ENTITY;

ENTITY xtdRelAssignsProperties
  SUBTYPE OF(xtdRelationship);
  RelatedProperties : SET [1:?] OF xtdProperty;
  RelatingObject : xtdObject;
END_ENTITY;

ENTITY xtdProperty
  SUBTYPE OF(xtdObject);
END_ENTITY;

ENTITY xtdRelAssignsMeasures
  SUBTYPE OF(xtdRelationship);
  RelatingProperty : xtdProperty;
  RelatedMeasures : SET [1:?] OF xtdMeasureWithUnit;
  MethodOfInterpretation : OPTIONAL xtdName;
END_ENTITY;

```

```

ENTITY xtdMeasureWithUnit
  SUBTYPE OF(xtdObject);
  UnitComponent : OPTIONAL xtdUnit;
  ValueDomain   : OPTIONAL LIST [1:?] OF xtdValue;
END_ENTITY;

ENTITY xtdUnit
  SUBTYPE OF(xtdObject);
END_ENTITY;

ENTITY xtdValue
  SUBTYPE OF(xtdObject);
  LowerTolerance : OPTIONAL xtdText;
  NominalValue   : OPTIONAL xtdText;
  UpperTolerance : OPTIONAL xtdText;
  ValueType      : OPTIONAL xtdValueTypeEnum;
  ValueRole      : OPTIONAL xtdValueRoleEnum;
  ToleranceType  : OPTIONAL xtdToleranceTypeEnum;
END_ENTITY;

ENTITY xtdName
  SUBTYPE OF(xtdLanguageRepresentation);
  Name       : xtdLabel;
  INVERSE
  is_name_of : SET [1:?] OF xtdRoot FOR Names;
END_ENTITY;

ENTITY xtdLanguageRepresentation
  ABSTRACT SUPERTYPE OF (ONEOF(xtdName, xtdDescription));
  LanguageName : xtdLanguage;
  UniqueID     : xtdGlobalUniqueID;
END_ENTITY;

ENTITY xtdDescription
  SUBTYPE OF(xtdLanguageRepresentation);
  Description : xtdText;
  INVERSE
  is_description_of : SET [1:?] OF xtdRoot FOR Descriptions;
END_ENTITY;

ENTITY xtdLanguage;
  LanguageNameInEnglish : xtdLabel;
  LanguageNameInSelf    : OPTIONAL xtdLabel;
  Comments               : OPTIONAL LIST [1:?] OF xtdText;
  UniqueID               : xtdGlobalUniqueID;
END_ENTITY;

ENTITY xtdRelCollects
  SUBTYPE OF(xtdRelationship);
  RelatedThings : SET [1:?] OF xtdRoot;
  RelatingCollection : xtdCollection;
END_ENTITY;

ENTITY xtdCollection
  ABSTRACT SUPERTYPE OF (ONEOF(xtdNest, xtdBag))
  SUBTYPE OF(xtdRoot);
END_ENTITY;

ENTITY xtdNest
  SUBTYPE OF(xtdCollection);
  WHERE

```

```

        WR1 : SIZEOF(QUERY(Result <* SELF\xtdRelCollects.RelatedThings |
NOT(TYPEOF(SELF\xtdRelCollects.RelatingCollection) = TYPEOF(Result)))) = 0 ;
    END_ENTITY;

ENTITY xtdBag
    SUBTYPE OF(xtdCollection);
END_ENTITY;

ENTITY xtdRelAssignsCollections
    SUBTYPE OF(xtdRelationship);
    RelatingObject      : xtdObject;
    RelatedCollections  : SET [1:?] OF xtdCollection;
END_ENTITY;

ENTITY xtdRelSequences
    SUBTYPE OF(xtdRelationship);
    RelatingActivity    : OPTIONAL xtdActivity;
    RelatedActivity     : OPTIONAL xtdActivity;
    WHERE
        WR1 : RelatedActivity:<>: RelatingActivity;
        WR2 : EXISTS(RelatingActivity) OR EXISTS(RelatedActivity);
END_ENTITY;

ENTITY xtdRelDocuments
    SUBTYPE OF(xtdRelationship);
    RelatedObjects      : SET [1:?] OF xtdObject;
    RelatingDocument   : xtdExternalDocument;
END_ENTITY;

ENTITY xtdExternalDocument;
    UniqueId           : xtdGlobalUniqueID;
    Names               : SET [1:?] OF xtdName;
END_ENTITY;

ENTITY xtdRelAssignsUnits
    SUBTYPE OF(xtdRelationship);
    RelatingMeasure     : xtdMeasureWithUnit;
    RelatedUnits        : SET [1:?] OF xtdUnit;
END_ENTITY;

ENTITY xtdRelAssignsValues
    SUBTYPE OF(xtdRelationship);
    RelatingMeasure     : xtdMeasureWithUnit;
    RelatedValues       : LIST [1:?] OF UNIQUE xtdValue;
END_ENTITY;

ENTITY xtdRelAssignsPropertyWithValues
    SUBTYPE OF(xtdRelationship);
    RelatedProperty     : xtdProperty;
    RelatingObject      : xtdObject;
    RelatedValues       : LIST [1:?] OF UNIQUE xtdValue;
END_ENTITY;

ENTITY xtdActor
    SUBTYPE OF(xtdObject);
END_ENTITY;

END_SCHEMA;

```

Bibliography

- [1] ISO 10303-11 Industrial automation systems and integration – Product data representation and exchange – Part 11: Description methods: EXPRESS language reference manual.
- [2] ISO 10303-41 Industrial automation systems and integration – Product data representation and exchange – Part 41: Fundamentals of product description and support.
- [3] ISO/CD 10303-221 Industrial automation systems and integration – Product data representation and exchange – Part 221: Application protocol: Functional data and their schematic representation for process plants.
- [4] ISO 12006-2 Building Construction – Organization of information about construction works – Part 2: Framework for classification of information.
- [5] ISO 15926-2 Industrial automation systems and integration – Integration of life-cycle data for oil and gas production facilities – Part 2: Data model.
- [6] ISO/PAS 16739 Industry Foundation Classes Release 2x Platform.
- [7] The Unicode Consortium. The Unicode Standard, Version 4.0. Boston, MA, Addison-Wesley, 2003. ISBN 0-321-18578-1.
- [8] ISO/IEC 10646 Information technology -- Universal Multiple-Octet Coded Character Set (UCS).

Appendix

Conventions

The following naming convention has been used in the development of this Standard. These conventions do not apply to the population or use of the framework.

1 Characters used for names

The characters [A-Z] upper case, [a-z] lower case, [0-9] numeric are used for names.

2 Case of names

Names are written in upper and lower case characters as a single name without spaces.

The first character of each word in normal usage following the schema prefix is written as an upper case character. All other characters forming part of the same word in normal usage are written in lower case characters.

3 Length of names

The length of names is not restricted.

4 xtd prefix

Names are prefixed by the term 'xtd' to identify their usage within the ISO 12006-3 Information Model. 'xtd' is an acronym for extensible taxonomy definition.

5 Names of entities other than relationship entities

The name of an entity is a noun or combination of nouns, denoting the 'content' or 'type' of the entity.

6 Names of relationship entities

Entities acting as relationships within the model contain the term 'Rel' following the 'xtd' prefix and before the name of the entity in normal usage. The inserted 'Rel' is treated as a word in normal usage and the 'Case of names' rule applied. Relationships are named starting from the related (SET [1:?]) of objects ending on the relating object. I.e. xtdRelComposes means that the relationship composes the parts (SET [1:?]) into a whole.

The name of the relationship entity is a verb or verb phrase that denotes the 'function' of the relationship.

7 Plural naming of aggregation

Names of attributes and relationships within an aggregation are expressed in the plural form.